

其余  $\nabla$  3.2

型号	A/mm	B/mm	C/mm	D/mm	E/mm	F/mm	G/mm
HGZQ0606D	600	600	800	100	380	380	120
HGZQ0906D	900	600	800	100	680	380	120
HGZQ1008D	1000	800	800	100	780	580	120
HGZQ1208D	1200	800	800	100	980	580	120
HGZQ1509D	1500	900	800	150	1200	600	200
HGZQ1510D	1500	1000	800	150	1200	700	200
HGZQ1512D	1500	1200	800	150	1200	900	200
HGZQ1609D	1600	900	800	150	1300	600	200
HGZQ1812D	1800	1200	800	200	1500	900	200
HGZQ1815D	1800	1500	800	200	1500	1200	200
HGZQ2010D	2000	1000	800	200	1720	700	200
HGZQ2012D	2000	1200	800	200	1720	900	200
HGZQ12412D	2400	1200	800	200	2120	900	200
HGZQ2415D	2400	1500	800	200	2120	1200	200
HGZQ3010D	3000	1000	800	200	2740	700	200
HGZQ3012D	3000	1200	800	200	2740	900	200

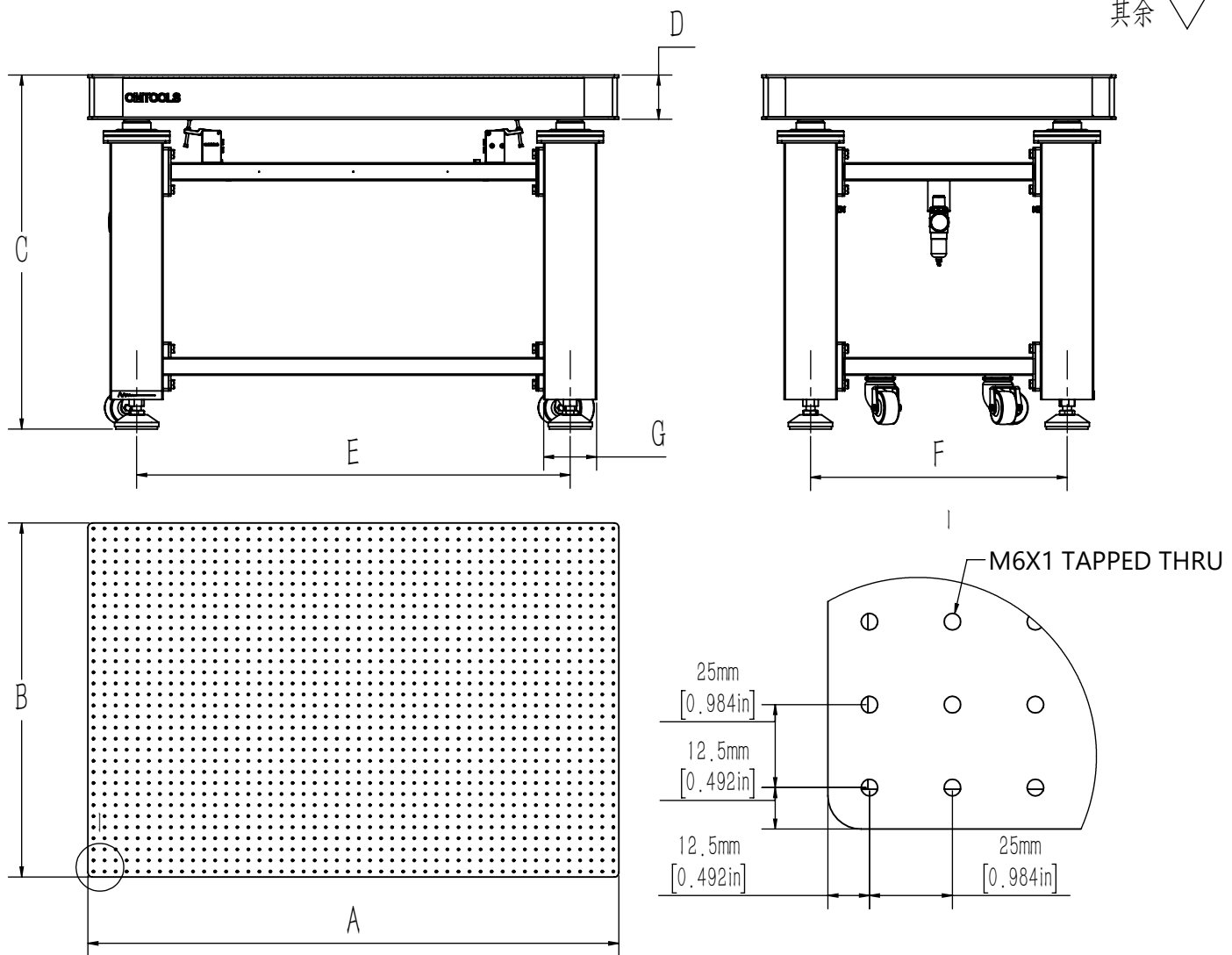

DRAWING PROJECTION					
REV	A0	HGZQ系列气浮平台 (4支腿)			
DRAWN	TODD			WEIGHT	SCALE
DATE	2022/3/21	kg	1:15		
FOR INFORMATION ONLY NOT FOR MANUFACTURING PURPOSES					