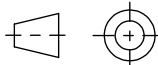

型号	A/mm	B/mm	C/mm	D/mm	E/mm	F/mm	G/mm	自重/ kg
HGZZ-0606Z	600	600	800	100	380	380	120	97
HGZZ-0906Z	900	600	800	100	680	380	120	120
HGZZ-1008Z	1000	800	800	100	780	580	120	153
HGZZ-1208Z	1200	800	800	100	980	580	120	180
HGZZ-1509Z	1500	900	800	150	1200	600	200	285
HGZZ-1510Z	1500	1000	800	150	1200	700	200	308
HGZZ-1512Z	1500	1200	800	150	1200	900	200	342
HGZZ-1609Z	1600	900	800	150	1300	600	200	309
HGZZ-1812Z	1800	1200	800	200	1500	900	200	429
HGZZ-1815Z	1800	1500	800	200	1500	1200	200	502
HGZZ-2010Z	2000	1000	800	200	1720	700	200	416
HGZZ-2012Z	2000	1200	800	200	1720	900	200	463
HGZZ-2412Z	2400	1200	800	200	2120	900	200	523
HGZZ-2415Z	2400	1500	800	200	2120	1200	200	625

DRAWING PROJECTION 		OMTOOLS	
REV	A0		
DRAWN	TODD	WEIGHT	SCALE
DATE	2023/5/4	kg	1:25
FOR INFORMATION ONLY NOT FOR MANUFACTURING PURPOSES			